

RESPONSE TO LETTER DATED 18 JUNE 2018

1. NOVELTY

Cited designs other than those designs circled in yellow in the attached comparison reference drawings differ from the subject design application in terms of overall shape, and thus are not similar to the subject design application.

On the other hand, the designs circled in yellow (designs 1 to 7) share a common general configuration with the subject design application. As such, comparing the subject design application and the designs circled in yellow (designs 1 to 7), and evaluating their common features and differences, reveals the following points.

(1) Comparison and Evaluation of the Subject Design Application and Designs 1 to 7

(1-1) Common Features

The subject design application and designs 1 to 7 share an approximately triangular prismatic shape in common when viewed in general.

(1-2) Evaluation of Common Features

As shown in attached document 1, prismatic triangular shaped abrasives are commonplace for abrasive designs, and so the common features of the designs have little visual impact and would not catch the attention.

(2-1) Differences

(2-1-1) Differences between the Subject Design Application and Designs 1 and 7

- Peripheral surfaces: The subject design application has peripheral surfaces that are shaped as approximate parallelograms when viewed from the side, whereas designs 1 and 7 have peripheral surfaces that are shaped as approximate rectangles and squares when viewed from the side.
- Silhouette: The subject design application has a curved silhouette with deformations, whereas designs 1 and 7 have rectilinear silhouettes with regular proportions.
- Corners: The subject design application has corners at which the approximately triangular surfaces and peripheral surfaces meet, and the angles of the three corners decline at the peripheral surfaces to form arched surfaces with large diameters. In contrast, designs 1 and 7 have sharp corners at which the approximately triangular surfaces and peripheral surfaces meet, forming arched surfaces with small diameters at the three corners of the peripheral surfaces.

(2-1-2) Evaluation of Differences between the Subject Design Application and Designs 1 and 7

The subject design application and designs 1 and 7 differ in terms of the shape of the

peripheral surfaces when viewed from the side. That is, the designs differ in terms of their basic constitution.

Additionally, these differences in the aspects of silhouettes and corners between the subject design application and designs 1 and 7 gives rise to conclusive differences in terms of impression. That is, the curved silhouette with deformations and the corners with declining angles of the subject design application give an unbalanced and rounded impression.

On the other hand, the rectilinear silhouette with regular proportions, the sharp corners and the formation of an arched surface with small-diameter corners of designs 1 and 7 give a balanced and sharp impression.

(2-2-1) Differences between the Subject Design Application and Designs 2 and 6

- Thickness: The subject design application has thickness, whereas designs 2 and 6 are flattened.
- Silhouette: The subject design application has a curved silhouette with deformations, whereas designs 2 and 6 have rectilinear silhouettes with regular proportions.
- Corners: The subject design application has corners at which the approximately triangular surfaces and peripheral surfaces meet, and the angles of the three corners decline at the peripheral surfaces to form arched surfaces with large diameters. In contrast, designs 2 and 6 have sharp corners at which the approximately triangular surfaces and peripheral surfaces meet, forming arched surfaces with small diameters at the three corners of the peripheral surfaces.

(2-2-2) Evaluation of Differences between the Subject Design Application and Designs 2 and 6

The subject design application and designs 2 and 6 give completely different impressions to each other.

That is, the curved silhouette with deformations and the corners with declining angles of the subject design application give an unbalanced and rounded impression. Since the subject design application also has thickness, the rounded impression is further emphasized.

On the other hand, the rectilinear silhouette with regular proportions, the sharp corners and the formation of an arched surface with small-diameter corners of designs 2 and 6 give a balanced and sharp impression. Since designs 2 and 6 are also flattened, the sharp impression is further emphasized.

The aspects of the peripheral surfaces of designs 2 and 6 when viewed from the side are unclear from the photographs. Even if the peripheral surfaces of designs 2 and 6 were approximately parallelograms when viewed from the side, as per the subject design application, this common feature would be overshadowed by the difference in impression given by the difference relating to the aspects of silhouettes, corners and thickness.

(2-3-1) Differences between the Subject Design Application and Design 3

- Peripheral surfaces: Acute-angled parts of the approximate parallelograms in peripheral

surfaces of the subject design are formed approximately 70 degrees. In contrast, acute-angled parts of the approximate parallelograms in peripheral surface of design 3 are formed less than 70 degrees and sharp-pointed.

- Silhouette: The subject design application has a curved silhouette with deformations, whereas design 3 has a rectilinear silhouette with regular proportions.
- Corners: The subject design application has corners at which the approximately triangular surfaces and peripheral surfaces meet, and the angles of the three corners decline at the peripheral surfaces to form arched surfaces with large diameters. In contrast, design 3 has sharp corners at which the approximately triangular surfaces and peripheral surfaces meet, forming arched surfaces with small diameters at the three corners of the peripheral surfaces.

(2-3-2) Evaluation of Differences between the Subject Design Application and Design 3

The subject design application and design 3 give completely different impressions to each other.

That is, the curved silhouette with deformations and the corners with declining angles of the subject design application give an unbalanced and rounded impression. Since Acute-angled parts of the approximate parallelograms in peripheral surfaces of the subject design are formed approximately 70 degrees, the rounded impression is further emphasized.

On the other hand, the rectilinear silhouette with regular proportions, the sharp corners and the formation of an arched surface with small-diameter corners of design 3 give a balanced and sharp impression. Since acute-angled parts of the approximate parallelograms in peripheral surface of design 3 are formed less than 70 degrees and sharp-pointed, the sharp impression is further emphasized.

(2-4-1) Differences between the Subject Design Application and Design 4

- Silhouette: The subject design application has a curved silhouette with deformations, whereas design 4 has a rectilinear silhouette with regular proportions.
- Corners: The subject design application has corners at which the approximately triangular surfaces and peripheral surfaces meet, and the angles of the three corners decline at the peripheral surfaces to form arched surfaces with large diameters. In contrast, design 4 has corners at which the approximately triangular surfaces and peripheral surfaces meet, and the angles of the three corners decline at the peripheral surface to form arched surfaces with small diameters.

(2-4-2) Evaluation of Differences between the Subject Design Application and Design 4

The subject design application and design 4 give completely different impressions to each other.

That is, the curved silhouette with deformations and the corners with declining angles of the subject design application give an unbalanced and rounded impression.

On the other hand, the rectilinear silhouette with regular proportions, the sharp corners and the formation of an arched surface with small-diameter corners of design 4 give a balanced and sharp impression.

The aspects of the peripheral surfaces of design 4 when viewed from the side are unclear from the photographs. Even if the peripheral surfaces of design 4 were approximately parallelograms when viewed from the side, as per the subject design application, this common appearance would be overshadowed by the difference in impression given by the difference relating to the aspects of silhouettes and corners.

(2-5-1) Differences between the Subject Design Application and Design 5

- **Silhouette:** The subject design application has a curved silhouette with deformations, whereas design 5 has a rectilinear silhouette with regular proportions.
- **Corners:** The subject design application has corners at which the approximately triangular surfaces and peripheral surfaces meet, and the angles of the three corners decline at the peripheral surfaces to form arched surfaces with large diameters. In contrast, design 5 has sharp corners at which the approximately triangular surfaces and peripheral surfaces meet, forming arched surfaces with small diameters at the three corners of the peripheral surfaces.

(2-5-2) Evaluation of Differences between the Subject Design Application and Design 5

The subject design application and design 5 give completely different impressions to each other.

That is, the curved silhouette with deformations and the corners with declining angles of the subject design application give an unbalanced and rounded impression.

On the other hand, the rectilinear silhouette with regular proportions, the sharp corners and the formation of an arched surface with small-diameter corners of design 5 give a balanced and sharp impression.

(3) Conclusion

The subject design application and designs 1 to 7 share a common general constitution. However, this general constitution is commonplace for this type of article, and so it has little visual impact.

On the other hand, the subject design application and designs 1 to 7 differ greatly in terms of the parts that define the formative tone of the aspects of silhouette and corners. This ensures that the designs give completely different impressions.

Consequently, the differences between the subject design application and designs 1 to 7 surpass the common features, and since the aesthetic appearances of the designs differ as a whole, the designs are dissimilar to each other.

As such, the novelty of the subject design application cannot be negated by designs 1 to 7 and the other cited designs.

2. ORIGINALITY

As shown in document 1, the approximately triangular prismatic shape of the constitution as a whole is commonplace for this type of article in view of the prior art.

Designs for this kind of article tend to share a common general constitution, and a new

design would be created by adding a refinement or modification to the details. In the case of the subject design application, the constitution has creative features in that the silhouette is deformed in a curved manner, and the angles of the corners decline to form an arched surface with a large diameter. This constitution is specific to the subject design application and is not possessed by any of the cited designs.

As such, the originality of the subject design application cannot be negated by the cited designs.

Comparison reference drawings

Application No. 61449

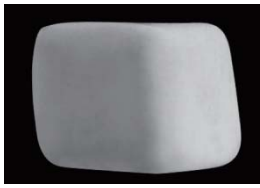

Front view



Top view



Bottom view



Right side view



Perspective view

The cited designs

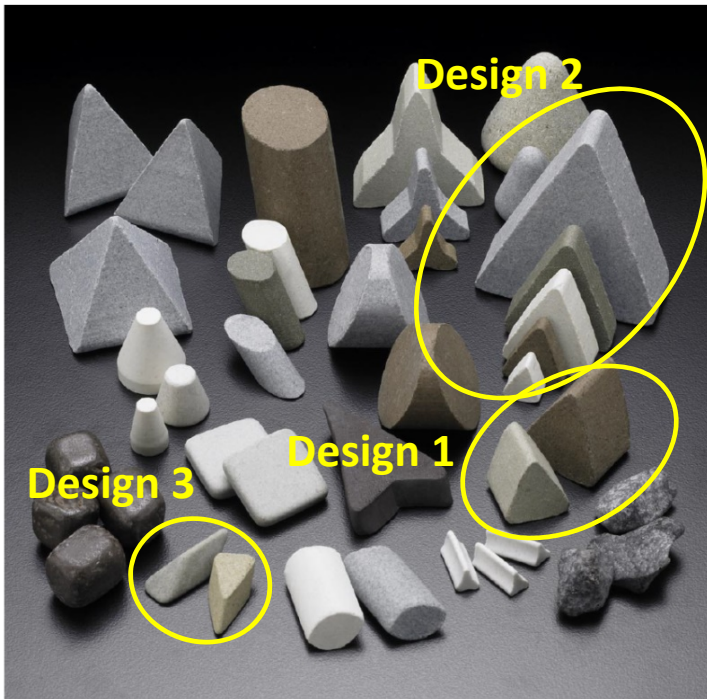

Document 1

Japanese Patent Application Publication
No. SHO 55-112764

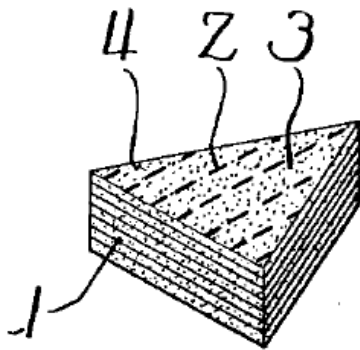

Japanese Patent Application Publication
No. HEI 10-244456

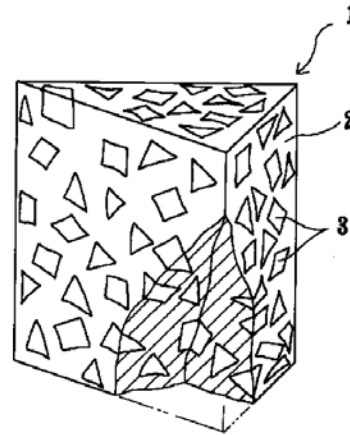

Japanese Patent Application Publication
No. 2018-94695

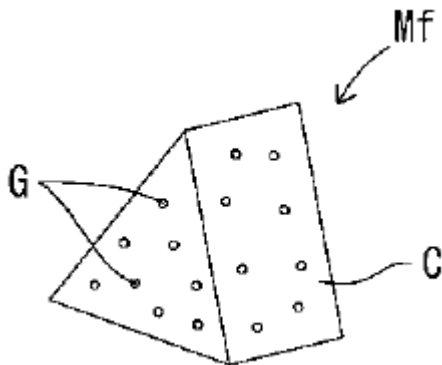

Re-publication of
PCT International Application
No. 2012/086679

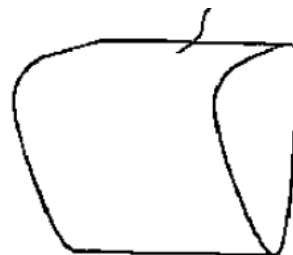

Japanese Patent Application Publication
No. 2003-231053

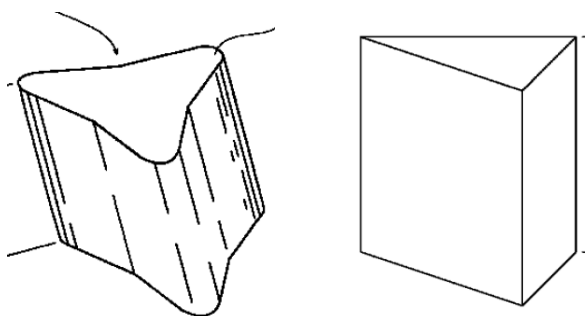

Argentina Design Registration No. 254

